

HB-LLC LED Driver Board

Prepared by: Fabien Franc & Roman Stuler
ON Semiconductor



ON Semiconductor®

<http://onsemi.com>

APPLICATION NOTE

Introduction

This document describes the Half-Bridge LLC (HB-LLC) evaluation board that includes an LLC resonant converter and LED driver circuitry. The HB-LLC board is targeting large LCD backlight applications where there is a need to drive long strings of LEDs of about 100 V forward voltage directly from a PFC converter output. The HB-LLC provides a high efficiency power conversion (PLED / PIN around 90%) and guarantees tight LED current matching between 6 LED strings.

The LED driver function is achieved by the ON Semiconductor CAT4026 6-channel LED controller. The CAT4026 drives six long strings of LEDs with an equivalent anode output voltage centered around 105 V (90 V min and 121 V max). The complete power-supply system includes an off-line PFC unit (or high voltage power supply), the HB-LLC board and the LED load, as shown in Figure 1. This note covers in detail the operation of the HB-LLC board.

The HB-LLC board controls up to 6 strings of LEDs and regulates the anode voltage by automatically adjusting to the highest LED string voltage and therefore providing optimum efficiency. The board provides open LED and shorted LED detection and protection.

The main supply consists of a high-voltage 400 V DC supply coming from the PFC boost unit which is powered directly from the AC lines as shown in Figure 1. The 400 V is regulated down in the HB-LLC board with the ON Semiconductor NCP1397 flyback resonant LLC half-bridge converter to generate the anode supply voltage for driving the LEDs. In addition to the 400 V, the PFC unit provides a regulated 15 V supply needed to bias the NCP1397 converter IC.

The LED load is connected externally to the HB-LLC board via a connector.

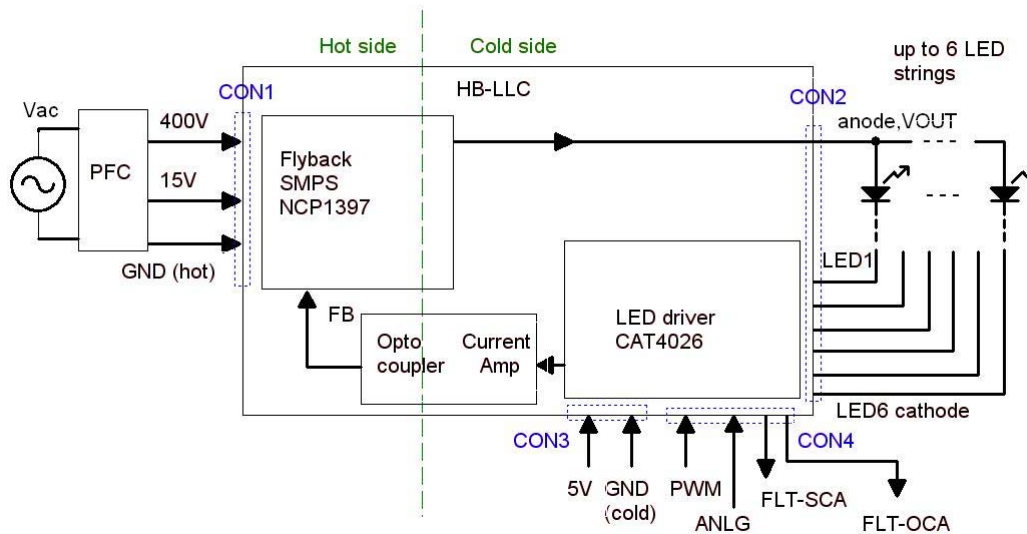

Figure 1. System Block Diagram

AND8479/D

Board Description

The HB-LLC evaluation board, shown on Figures 2 and 3, provides an isolated power supply with the NCP1397A resonant mode controller circuitry (on the left side) and the CAT4026 6-channel LED controller circuitry (on the right side).

The NCP1397A circuitry converts the 400 V supply to a dynamically adjustable anode voltage to power the LED strings. The CAT4026 linear driver controls the constant current in each of the 6 LED channels using external power transistors to regulate the LED current.

The CAT4026 provides a current feedback (IFB) output connected through a current amplifier (4x) and the optocoupler back to the NCP1397 feedback (FB) pin to automatically adjust the anode voltage to the minimum level required to drive the LEDs.

LED current dimming can be achieved in two ways, PWM dimming using the PWM input, or analog dimming with the analog voltage ANLG input.

A 15 V DC supply from the PFC unit (hot side) powers the NCP1397A controller. A 5 V DC external power supply is required to power the CAT4026 LED controller and is also connected to the optocoupler (cold side).

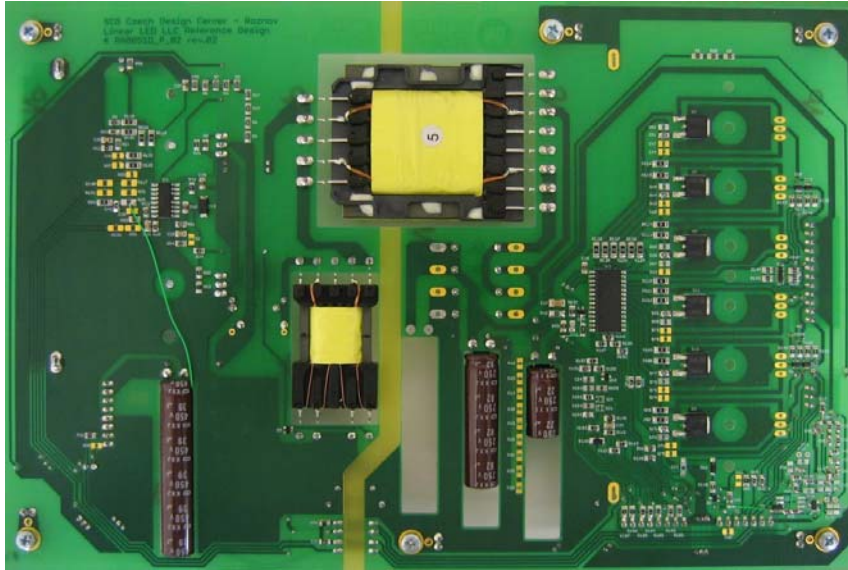

Figure 2. HB-LLC Board – Top Side

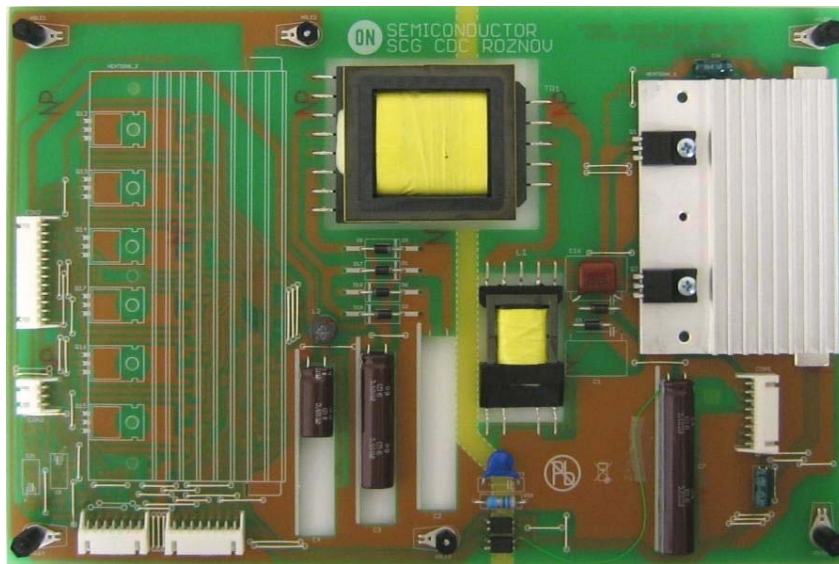

Figure 3. HB-LLC Board – Bottom Side

Detailed Operation

The board includes a half-bridge LLC power stage and an LED driver section. Each section is described below.

LLC Power Stage Operation

The following sections describe the 130 V/1 A output LLC power stage intended for use as a main power converter in ON Semiconductor's linear LED backlight reference design. This power stage provides insulation and regulated voltage to the linear LED current regulator driven by the CAT4026 controller. Output voltage of the LLC stage is controlled by the CAT4026 from the secondary side to provide optimum voltage for the LED string with the highest forward voltage.

Topology Overview

The power stage uses a Half Bridge Resonant LLC topology since it provides several beneficial features:

- Limited number of components (no secondary regulation coil needed)
- Small size resonant inductance
- Zero Voltage Switching (ZVS) condition for primary switches under all load conditions
- Zero Current Switching (ZCS) for secondary diodes under all load conditions
- Higher power density than other topologies: better fit for SLIM design

The selected LLC power stage topology improves efficiency, reduces EMI signature and provides better transformer utilization compared to conventional topologies. The NCP1397A is used as a controller for this power stage.

Consideration was also given to optimize the step load transient response and transformer audible noise as the LCD TV backlight application works permanently under on/off mode as required in linear PWM dimming mode operation.

Table 1 shows the specifications of the main power stage.

Table 1. LLC POWER STAGE SPECIFICATION

Requirement	Min	Max	Unit
Input Voltage (DC)	350	425	V
Output Voltage (DC)	80	125	V
Output Current	0	1	A
Total Output Power	0	150	W

The NCP1397A provides the following beneficial features to an LLC power stage:

Brown-Out (BO) Protection Input

The BO input pin has two functions. First, the BO input permanently monitors the bulk voltage and ensures the SMPS works in the proper V_{bulk} range. The second function is to latch-off the device when the BO input is pulled above 4 V. The BO latch could be used to provide OVP (overvoltage protection) or OCP (overcurrent protection) if needed.

Timer Based Fault Protection

The controller stops operation after a programmed delay when the overload condition occurs. Under transient loading conditions, the converter output will not be turned off, unless the overload conditions exceed the user programmed timeout.

Two Level Overcurrent Protection

The primary current of an LLC stage can grow to excessive values when overload occurs on the output. The NCP1397A features OCP comparator that speeds-up the fault timer duration in case short circuit appears in the application.

Adjustable Dead-Time (DT)

The NCP1397A/B provides the designer flexibility in adjusting the appropriate dead time to protect switches against cross-conduction. The length of the DT is chosen based on the total output capacitance of MOSFETs used in the application. If the DT is too short, there is not enough time to re-charge this capacitance and the opposite MOSFET is turned on under "hard switching conditions". The result is poor efficiency and EMI. On the other hand, it is not good to choose a DT too long as the resonant tank stores only a finite amount of energy to maintain ZVS condition.

Adjustable Minimum and Maximum Frequency Excursion

Using external resistor, the designer can program its lowest frequency point, obtained in lack of feedback voltage. Internally trimmed capacitors offer a 3% precision on the selection of the minimum switching frequency. The maximum operating frequency clamp is less critical for application thus the NCP1397 provides tolerance of 12% maximally.

Open Feedback Loop (FB) Detection

Upon start-up or during operation, if the FB signal is missing, the fault timer starts to charge timer capacitor. If the loop is really broken, the FB level does not rise before the timer ends charging. The controller then stops all pulses and waits until the timer pin voltage collapses to 1 V typically before a new attempt to re-start. A hiccup takes place if the FB fault is permanently present in the application.

High Side HV Driver

The NCP1397 enables direct connection of the high side MOSFET Q1 thanks to built-in high side driver (HSD). This "floating" driver accepts voltages up to 600 V and features high dV/dt immunity. The HSD is powered from bootstrap capacitor that is refilled through a bootstrap diode. Under-voltage detection ensures the high side MOSFET will be turned on only if there is enough voltage to properly drive the MOSFET.

Please refer to the datasheet for more information and a detailed description of the NCP1397A/B LLC controller.

Detailed Power Stage Description

A complete schematic of the power stage is shown in Figure 23. Partial schematics are used in the following descriptions for better clarity.

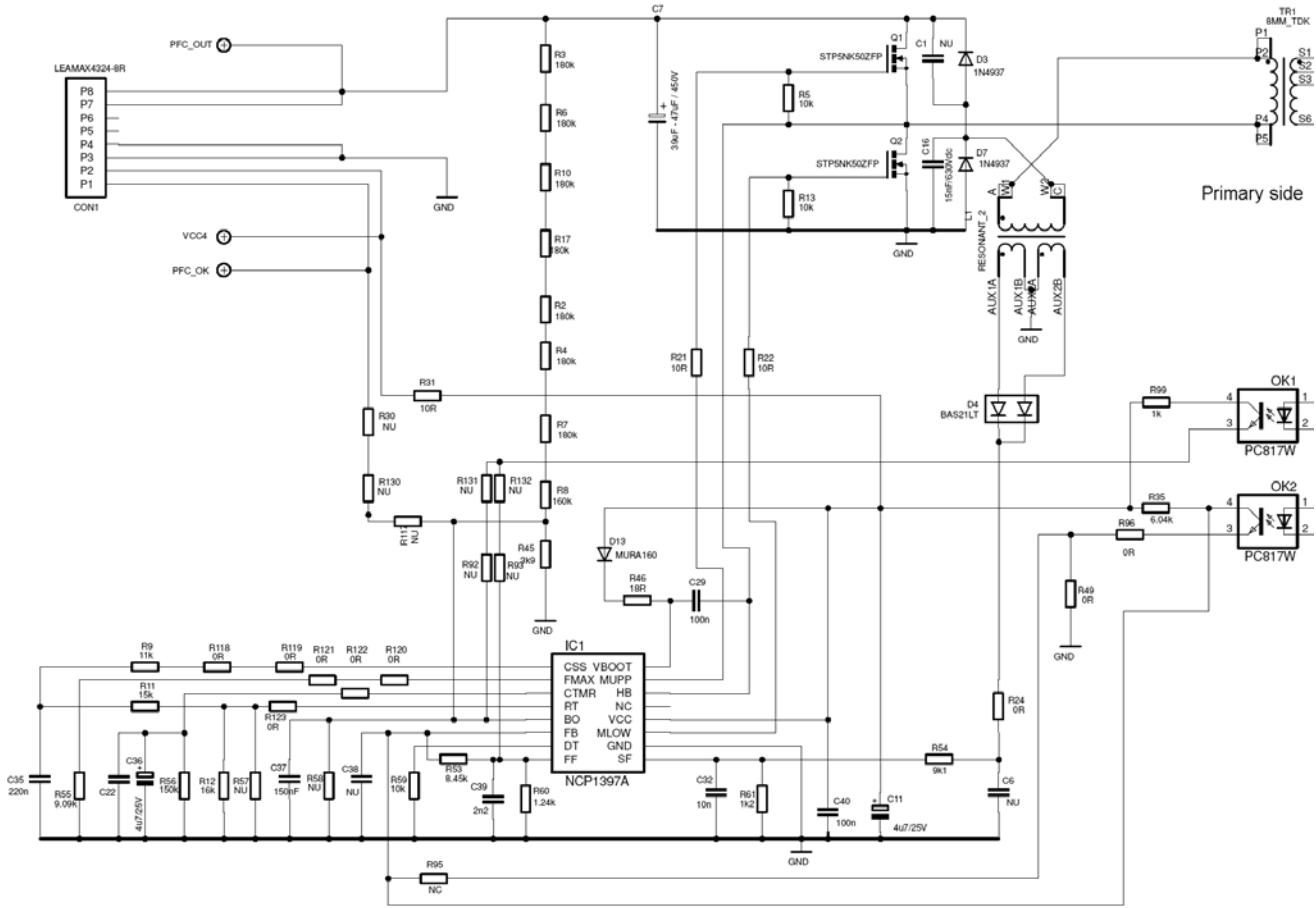

Figure 4. The LLC Stage Connection – Primary Side

Primary Side Power Loop Connection

The output voltage of the PFC stage is connected to capacitor C7 via input connector CON1. Connector CON1 pins P7 and P8 are the 400 V + V_{bulk} terminal, and pins P3, P4 are the GND terminals (refer to Figure 4). Capacitor C7 provides filtering of the high frequency LLC stage primary current. Another purpose of the capacitor C7 is to deliver energy to the LLC stage during transient loading (together with bulk capacitors that are present in PFC stage). The LLC stage power loop is closed through transistors Q1 and Q2, transformer TR1, resonant coil L1 and resonant capacitor C16. The NCP1397A LLC controller features 600 V high-side gate driver and is capable of driving the HB power stage directly without the use of a driver transformer. Resistors R21 and R22 are used to suppress ringing and control EMI noise on the power MOSFET gates. Bootstrap capacitor C29 provides the energy required for controlling the high side MOSFET. When Q2 is turned-on, the HB pin voltage drops and bootstrap capacitor C29 is charged through resistor R46 and high-voltage diode D13. At turn-on and after any restart, the LLC controller turns on MOSFET Q2 first to charge up the bootstrap capacitor.

The LLC controller is powered from the independent auxiliary power supply 15 V VCC connected to the connector CON1 pin P2. Resistor R31 together with capacitor C11 forms local filter to assure decoupling of the controller supply voltage from other blocks.

Brown-out Protection and Fault Latch

The LLC converter provides excellent parameters over a specific bulk voltage range only. Thus it is needed to monitor the PFC output voltage and turn the LLC controller off in case the bulk voltage drops. Resistor divider R2, R3, R4, R7, R8, R10, R17 and R45 provides LLC controller with bulk voltage information. The resistor divider ratio has been calculated in such a way that the application starts operation for V_{bulk} greater than 380 Vdc and turns-off when V_{bulk} drops below 350 V. Capacitor C37 is used to filter Brown-out pin voltage to overcome unwanted latch of the device due to noise that is always present in switching applications.

Some of the PFC stages feature PFC_OK output flag. The Brown-out divider from V_{bulk} is then not needed. The

PFC_OK signal can be brought to the BO input from the input connector CON1 (pin P1) via resistors R30, R130 and R117.

In addition to the basic Brown-out function, the BO input can also be used to latch-off the device in case of a secondary fault. The optocoupler OK1, which is activated by a secondary fault signal, pulls up the BO pin via resistors R92, R131 and thus latches application fully off. The LLC controller can be then restarted only via Vcc restart.

The latch-off state after fault detection is not acceptable in some applications. This reference design provides also another alternative – i.e. to stop the application only during the time the fault flag is present. This is done using NCP1397A skip/enable input. The OK1 pulls up the skip/enable input via resistors R93, R132 when these are implemented.

FB Loop and Skip Mode

The minimum operating frequency of the LLC stage is set by resistor R12 connected to the Rt pin (refer to Figure 5). The maximum operating frequency is set by resistor R55 connected to the FMAX pin. The LLC stage will reach maximum operating frequency during no load conditions – before entering skip mode.

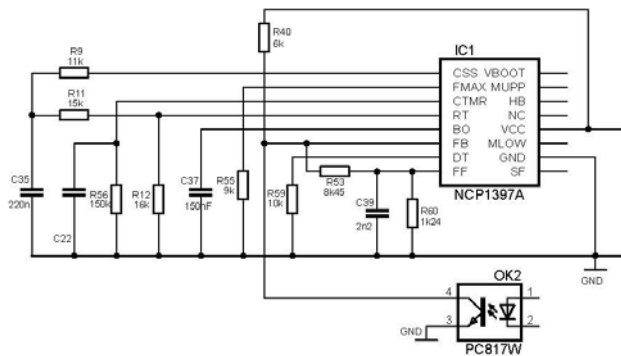

Figure 5. The Primary FB Loop and Skip Mode Circuitry Connection

Secondary regulator (CAT4026) drives optocoupler OK2 and thus provides feedback to the primary side. The optocoupler current adjusts the FB pin voltage. The LLC stage operating frequency is thus modulated to assure output voltage regulation. Resistor R40 is implemented to pull up the FB pin in case of light load conditions or when the secondary regulator path is opened. Application then naturally increases operating frequency and/or stops operation – thus reducing output voltage. The internal FB fault comparator present in the NCP1397 LLC controller turns the application off after programmed time out in case there is no voltage present on the FB pin. Application is thus protected against overpower or short circuit on the FB pin of the primary side.

The LCD TV backlight application works permanently in dimming mode. This means that the LLC converter delivers nearly zero output power for certain time within dimming

period (depends on the PWM input dimming signal duty cycle). As already mentioned above, the LLC controller stops the power stage operation via skip/disable pin in such case. The FB pin voltage increases when the load diminishes. Once the load current is too low, the LLC stage is not able to maintain regulation because the operating frequency cannot increase further (Fmax clamp – resistor R55). The FB voltage then increases above the Vfb_max limit of 5.3 V. The resistor divider R53 and R60 provides the FB pin voltage to the Skip/Fault input. The output drivers are thus automatically turned-off and the device terminates operation until the skip/disable input voltage does not drop down again.

Overload and Short Circuit Protection

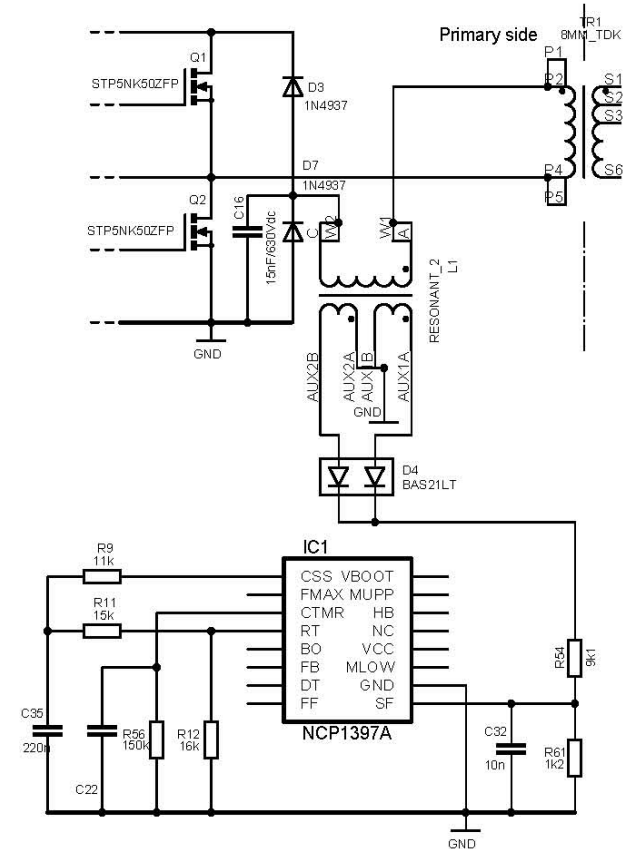

Figure 6. The Output Overload and/or Short Circuit Protection

The Over Current Protection (OCP – Figure 6) is implemented in this reference design to protect the application against overload conditions. The primary current is sensed indirectly by monitoring the resonant inductor flux. Voltage from auxiliary windings is rectified by dual diode D4, scaled down by resistor divider R54, R61, filtered by capacitor C32 and connected to the fault input of the LLC controller.

The Soft Start capacitor discharge switch on CSS pin 1 is turned-on once the Fault/SF pin 9 voltage reaches the VRef_fault threshold (1.04 V). The LLC stage operating

frequency is thus automatically increased as the Soft Start capacitor voltage drops and higher current flows out from the RT pin. The frequency shift naturally reduces the primary current and protects the primary MOSFETs against excessive overcurrent. The Itimer1 current source is activated on pin 3 simultaneously and external timing capacitor C22 begins charging. If the overload condition lasts longer than the time given by the timer pin components (C22, R56), the controller enters protection mode and output drivers are disabled. Once timer capacitor C22 is discharged to 1 V by resistor R56, the application attempts to restart via Soft Start.

The fault timer duration is too long to protect the application against damage due to a short circuit on the secondary side (output terminals short or secondary transformer winding short). To protect against this possibility, there is a second OCP comparator monitoring the fault pin voltage. When the frequency shift (via Soft Stat pin and resistors R9, R11) is no longer sufficient to keep the primary current limited, the fault input voltage reaches the

Vref_OCP threshold (1.55 V). The controller then increases timer capacitor charging current to shorten fault timer period and protect the power stage components from thermal damage.

Additional hardware cycle-by-cycle overcurrent protection has been implemented in this design to optimize power MOSFETs cost, peak power capability and transient response in dimming mode. This hardware protection is formed by two HV clamping diodes D3, D7. Resonant capacitor voltage is clamped to Vbulk level and thus the maximum peak power and primary current are limited.

In summary, the hardware OCP protection protects primary switches against damage due to high peak current that may occur during transformer secondary winding short. The fault management of the LLC controller then protects application against average overload induced by secondary overcurrent. This technique allows the application to deliver high peak power needed during startup and recovery from disable mode while keeping precise average overcurrent threshold.

LLC Power Stage Secondary Side

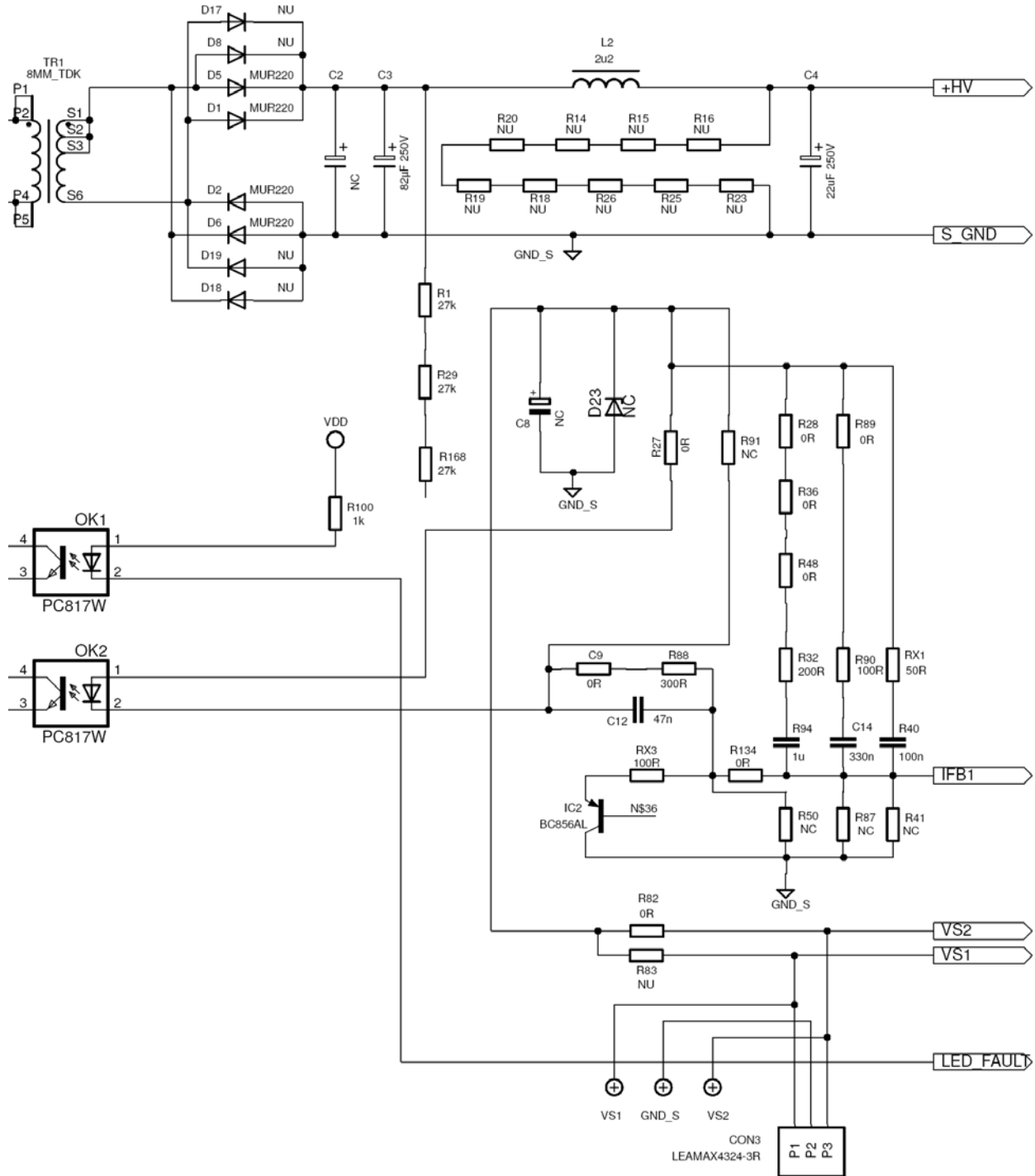

Figure 7. The LLC Secondary Side Schematic

Full bridge rectification is used on the secondary side. The efficiency degradation compared to the solution with center taped windings is negligible as the nominal output current is rather small. Advantage of this solution lies in the transformer design and construction simplification which impacts cost. PCB design features positions for two kinds of

leaded rectifiers (DO201 or DO41) to allow for output current increase if needed.

Capacitor C2 provides main filtering of the LLC stage output current. A single 82 µF capacitor has been used to achieve acceptable output voltage ripple and to minimize transformer audible noise during dimming operation. Of

course one needs to check whether the selected capacitor is able to handle corresponding RMS current (refer to [11] on how to design secondary filtering capacitor in LLC converter).

Capacitor C2 provides the bulk of filtering for the secondary current, but it does not fully filter out narrow glitches produced when the secondary winding reverses. Thus an additional LC filter (L2, C4) has been implemented. The resonant frequency of this filter should be as low as possible, however, it can affect system loop gain if the selected frequency is too close to the crossover frequency. A resonant frequency of 23 kHz has been selected for this design. The filter inductor of 2.2 μH features acceptable DC resistance. A filtering capacitor C4 of 22 μF (low impedance type) has been implemented. The filter provides higher peaking around the resonant frequency when a low ESR capacitor is used. On the other hand, if a capacitor with too high ESR is used, the output voltage drop during fast transient loading increases.

The output regulation is assured by the CAT4026 linear LED driver. The IFB pin of the CAT4026 provides control current from the optocoupler OK2 via bipolar transistors Q3 and Q19.

Resonant Tank and Transformer Design

An LLC resonant tank with external resonant coil has been selected in this reference design for several reasons:

Ultra low profile solution: The transformer with high leakage inductance (or resonant tank with integrated resonant inductance) cannot be easily used in low profile solutions. This is because the application metal cover is placed too close to the transformer. Transformers with high stray flux induce eddy currents into the metal cover that generates significant losses and affects resonant tank parameters. A standard transformer with minimum leakage inductance features only small stray flux and does not cause any issues. External resonant inductance with shielded gap is then needed to increase total resonant inductance value.

Transformer Winding Window Utilization

The winding window is usually purely used in transformer designs with high leakage inductance. This is because the primary and secondary windings have to be separated enough to reach required leakage. Another disadvantage of this solution is that special transformer bobbin is needed. The standard transformer with low leakage is much easier to design with lower manufacturing cost.

Design Flexibility

Specific LLC stage design requires specific magnetizing and resonant inductance values to achieve required gain over a given range of operating frequencies. The resonant tank with external resonant coil provides much more design flexibility because it allows simple adjustment of both mentioned parameters.

Cheap Primary Current Sensing

Flux of the external resonant coil can be easily sensed by an auxiliary winding. A cost effective current sensor can be implemented compared to traditional solutions which require HV charge pump capacitors.

The resonant tank is designed in such a way that the LLC stage is operated in, or very close to, the series resonant frequency (fs) for full load conditions and nominal bulk voltage. Efficiency is optimized for these operating conditions. The LLC stage operating frequency is increased up to 235 kHz to maintain output voltage regulation when the load diminishes. When the output load drops further, the maximum operating frequency clamp is reached and the application enters skip mode operation to maintain output voltage regulation and to reduce the LLC stage power losses. On the other hand, when the bulk voltage drops, the secondary regulator decreases the LLC stage operating frequency down to 118 kHz to achieve the necessary gain for output voltage regulation. Please refer to AND8460 for detail design steps of an LLC resonant tank circuitry.

As mentioned above, the bridge rectifier has been used in this design. This arrangement allows replacing center tapped secondary winding configuration. Center tap winding configuration is not suitable for applications with high output voltage / low output current because it complicates transformer design while providing only negligible efficiency increase. The situation is even more critical in LLC converter as both secondary windings needs to be well matched to overcome circuitry imbalance.

Final specification of resonant tank we used in this application is as follows:

- Resonant inductance Ls = 100 μH
- Resonant capacitor Cs = 15 nF
- Transformer magnetizing inductance Lm = 350 μH
- Transformer turns ratio n = 36/23
- Transformer leakage inductance Llk= 9.5 μH

The LLC stage gains needed for output voltage regulation under full load conditions and selected bulk voltage range (350 Vdc – 425 Vdc) can be calculated based on Equations 1 – 3.

$$G_{min} = \frac{2 \cdot (V_{out} + V_f)}{V_{bulk_max}} = \frac{2 \cdot (80 + 1.4)}{425} = 0.38 \quad (\text{eq. 1})$$

$$G_{nom} = \frac{2 \cdot (V_{out} + V_f)}{V_{bulk_nom}} = \frac{2 \cdot (100 + 1.4)}{396} = 0.51 \quad (\text{eq. 2})$$

$$G_{max} = \frac{2 \cdot (V_{out} + V_f)}{V_{bulk_min}} = \frac{2 \cdot (125 + 1.4)}{350} = 0.72 \quad (\text{eq. 3})$$

Where:

- Vf – is the expected drop of the rectification
- Vbulk_max – is the maximum operating bulk voltage
- Vbulk_nom – is the nominal operating bulk voltage
- Vbulk_min – is the minimum operating bulk voltage
- Vout – is the required output voltage (including worst case conditions i.e. temperature drift of the LED string).

AND8479/D

A simulation model can be built to verify the full load gain characteristic of the proposed LLC design with external resonant inductor (Figure 8).

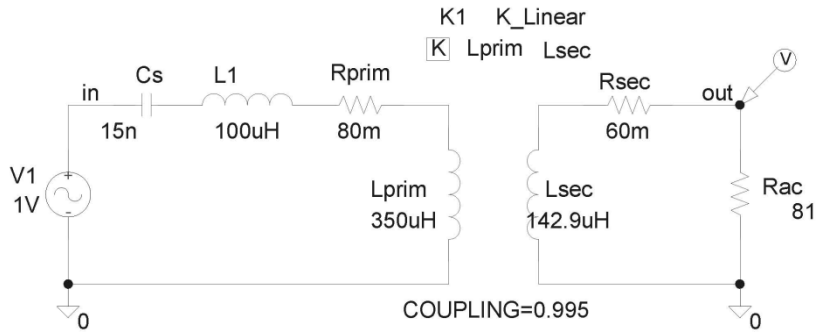

Figure 8. Simulation Model for the LLC Stage with External Resonant Inductance

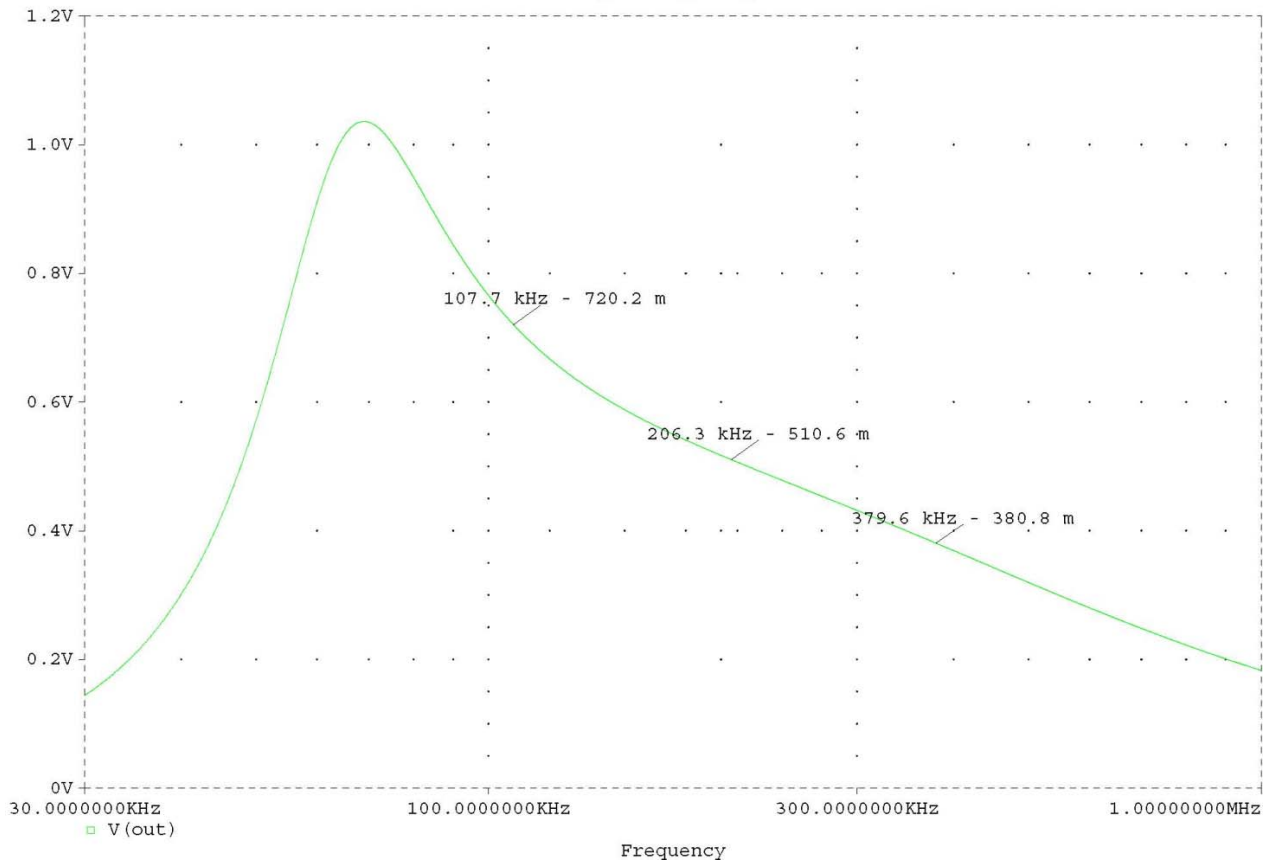

Figure 9. Simulated Gain Characteristic for the LLC Stage Design with External Resonant Inductance, Full Load Conditions

The simulated full load gain characteristic can be seen in Figure 9. Application features enough gain to cover whole output voltage operating range including V_{bulk} and LED string forward voltage variations.

LED Driver Operation

The CAT4026 controller regulates the current independently in the 6 LED strings by using external NPN power transistors and monitoring the voltage across the sense resistors tied to ground. Accurate constant current is guaranteed in each string so that the device is ideal for large LCD backlight applications. The controller senses each cathode string voltage and provides an output current feedback (IFB pin) to be interfaced to a DC/DC converter for automatically adjusting the anode voltage to the lowest level and therefore maximizes the power supply efficiency. The CAT4026 also detects shorted LEDs within a string or an open LED string fault condition. Both PWM and analog voltage inputs are available for dimming control.

LED Current Setting

The HB-LLC board is configured for LED current of 100 mA per channel. The LED current is set by external resistors (10 Ω) located between each CAT4026 RSET[x] pin and GND, as shown on Figure 10, and can be calculated as follows:

$$\text{LED current} = \frac{V_{\text{RSET}}}{R_x} = \frac{1 \text{ V}}{10 \Omega} = 100 \text{ mA} \quad (\text{eq. 4})$$

The LED current can be changed by replacing discrete resistors. The following formula is used to set the LED channel current:

$$R_x = \frac{1 \text{ V}}{\text{LED current}} \quad (\text{eq. 5})$$

Anode Voltage Range

The board is configured such that the anode voltage (VOUT) cannot exceed 122 V in operation. This is not a limitation of the CAT4026 but a limit set by an external resistor divider (R42, R43) connected to the OCA pin. If the anode voltage reaches a threshold of 122 V, the OCA fault flag (FLT-OCA output) is triggered. The board is set-up to accommodate LED strings with a total forward voltage of around 105 V typical at nominal current (range between 95 V and 121 V).

In normal operation (PWM high), the anode voltage is equal to the highest total LED forward voltage plus the cathode voltage (3.6 V typical) of the LED string.

On the HB-LLC board, the CAT4026 IFB current feedback in conjunction with the current amplifier (4x) via the optocoupler controls the NCP1397 FB feedback which sets the anode voltage. The IFB pin can sink up to a maximum of 1 mA current.

Fault Protection

The CAT4026 can detect two types of fault conditions: open cathode-anode (OCA) caused by an open LED, and short cathode-anode (SCA) caused by an LED string voltage mismatch.

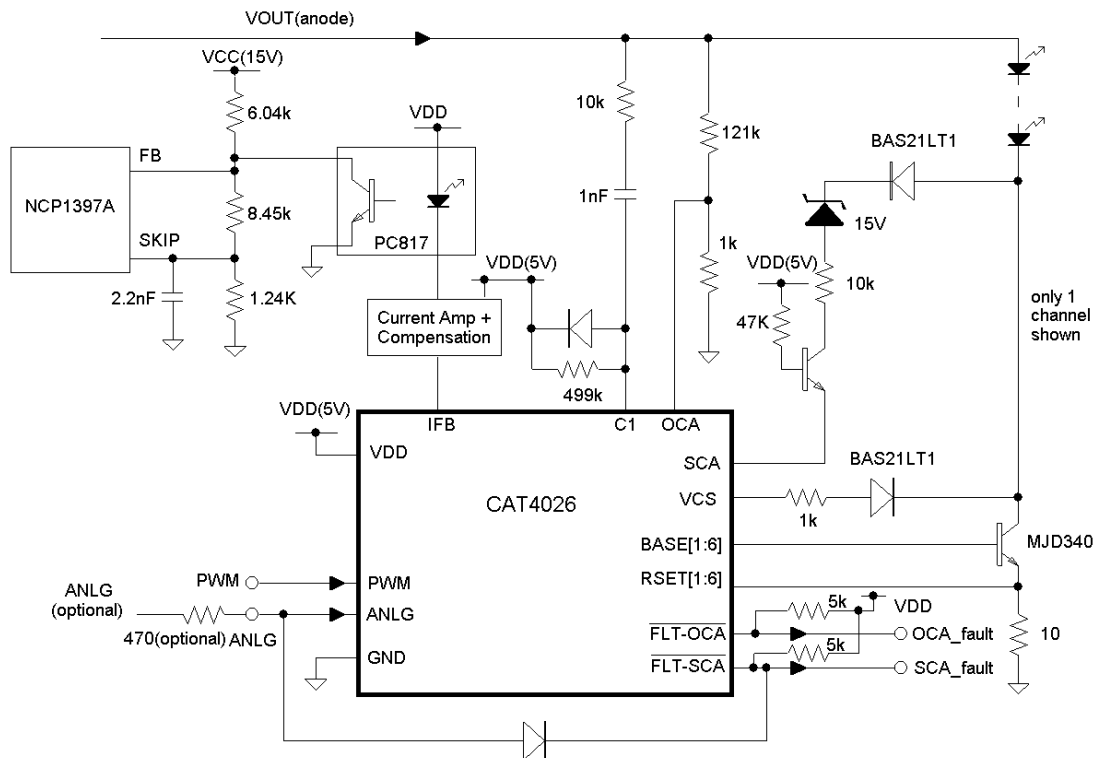

Figure 10. Partial Schematic Around the CAT4026 (only 1 channel shown)

Open LED

To protect against an LED channel being open-circuit, the maximum anode voltage is set on the HB-LLC board to 122 V. An open cathode-anode (OCA) fault is triggered once the CAT4026 OCA pin voltage exceeds the 1 V threshold. On the HB-LLC board, a resistor divider (R42, R43) sets the open LED anode threshold (VOTH) to 121 V, as follows:

$$V_{OTH} = \frac{1 \text{ V} \cdot (R42 + R43)}{R42} = \frac{1 \text{ V} \cdot (1 \text{ k} + 121 \text{ k})}{1 \text{ k}} = 122 \text{ V} \quad (\text{eq. 6})$$

The $\overline{\text{FLT-OCA}}$ open drain output is pulled low (active low) and latched once the OCA fault is detected. Any open-channel will automatically be disabled and removed from the feedback loop when the OCA fault is triggered. The remaining “good” channels can continue to operate normally.

The $\overline{\text{FLT-OCA}}$ output is cleared only once the CAT4026 enters shutdown mode.

Shorted LED

In case there is a large mismatch between LED string forward voltage, such as the occurrence of a short between several LEDs (anode to cathode), the power dissipated in the external BJT transistors (Q6 to Q17) can become very large causing the transistor package temperature to increase excessively. The CAT4026 can detect a large voltage mismatch of about 28 V or greater by sensing the cathode voltages and detecting an SCA fault condition via the SCA input pin. This SCA fault activates the $\overline{\text{FLT-SCA}}$ open-drain output (active low). A derating circuitry on the board decreases the LED current to 20% of nominal when the SCA fault is on. The SCA pin is connected to each LED cathode via a diode array and a voltage level translator. The threshold voltage of the detector can be adjusted by using an external Zener diode (D16) with 15 V breakdown in series with a 10 k Ω resistor. An unlatched signal will be produced by the $\overline{\text{FLT-SCA}}$ pin. The fault $\overline{\text{FLT-SCA}}$ output is connected to the ANLG pin through a diode (R160) and pulls the ANLG pin lower to 0.6 V when the SCA fault is present ($\overline{\text{FLT-SCA}}$ low), thereby limiting the current in each channel to 0.6 V/3 V x 100 mA or 20 mA.

Figure 22 shows the operation of the SCA fault occurrence during power-up.

Dimming Control

LED dimming can be done by two methods: PWM dimming using the CAT4026 PWM input, or analog dimming using the ANLG input.

For PWM dimming, the duty cycle of the PWM input signal sets the brightness. A function generator can be set with a 100 to 300 Hz frequency and 5 V amplitude output and connected directly to the PWM input on the connector CON4 P8. For full LED brightness, the PWM input should be connected to the 5 V supply.

The ANLG input (CON4 P7) is connected on the board to a 5 k Ω pull-up to the 5 V supply. So there is no need to drive the ANLG input externally (outside the board), ANLG is pulled high in normal operation (no analog dimming). If analog dimming is desired, a supply voltage can be connected the ANLG input externally through a 500 Ω resistor to limit the current in case the $\overline{\text{FLT-SCA}}$ fault turns on. An ANLG voltage below 3 V will dim the LEDs linearly.

Feedback Circuit

The anode output voltage (VOUT) is controlled by the CAT4026 IFB current feedback as shown in Figure 11. The IFB pin sink current (1 mA max) is amplified by a current mirror amplifier (4x) and drives the optocoupler which controls the NCP1397 feedback FB pin voltage. The IFB pin can sink up to a maximum of 1 mA current, with a typical of 0.5 mA in operation which translate in 4 mA max and 2 mA typical in the optocoupler diode.

When PWM input is kept low, the CAT4026 is in shutdown mode and the IFB pin does not sink current. Therefore the optocoupler diode is not conducting. The NCP1397A feedback FB pin voltage is around 7.7 V and the SKIP pin is high at about 1 V (above the 0.66 V threshold) which triggers the skip/disable mode. The LLC is not switching. The anode voltage VOUT is zero volt. All LEDs are off.

When PWM input is high (with 100 V LED string at 600 mA total load current), the CAT4026 is turned on and the IFB pin current is around 0.3 mA. The optocoupler diode is on. The NCP1397A feedback FB pin voltage is around 4.74 V and the SKIP pin voltage is about 0.61 V (below the threshold). The LEDs are on.

AND8479/D

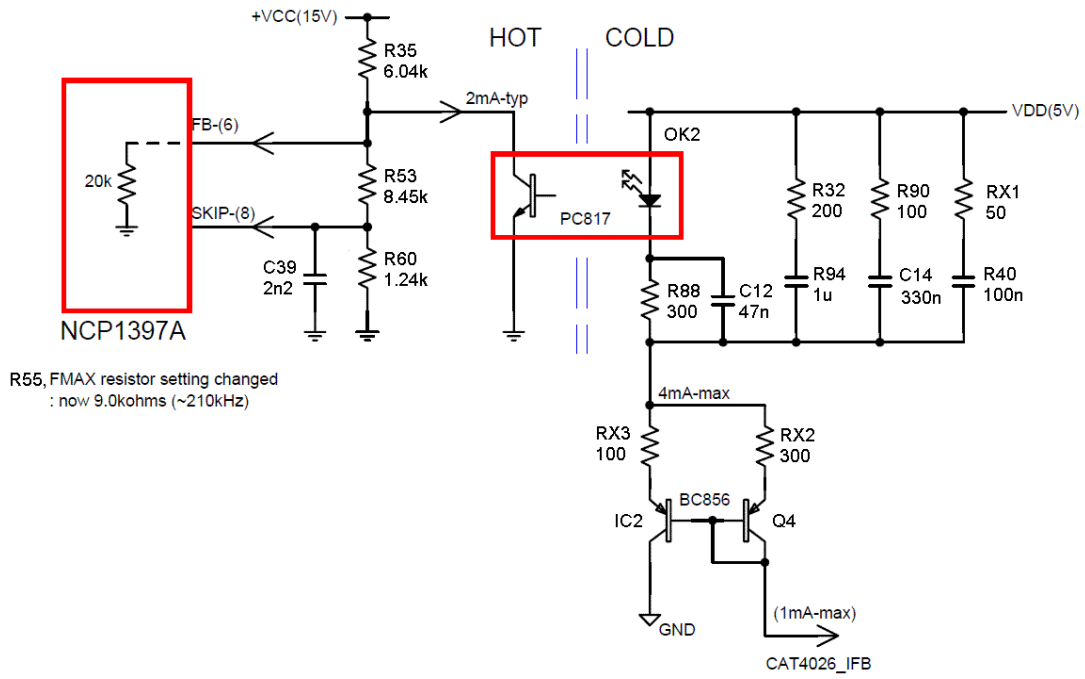

Figure 11. Feedback Circuitry

TYPICAL CHARACTERISTICS

Below are shown some typical transient waveforms during power-up, PWM dimming, and under open LED and shorted LED fault conditions.

Normal Operation

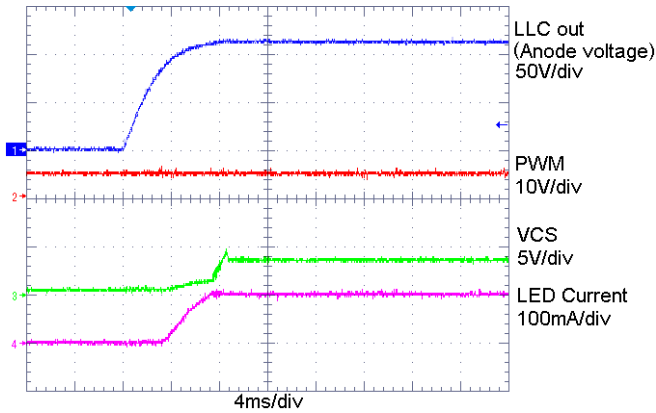

Figure 12. Power Up with PWM High

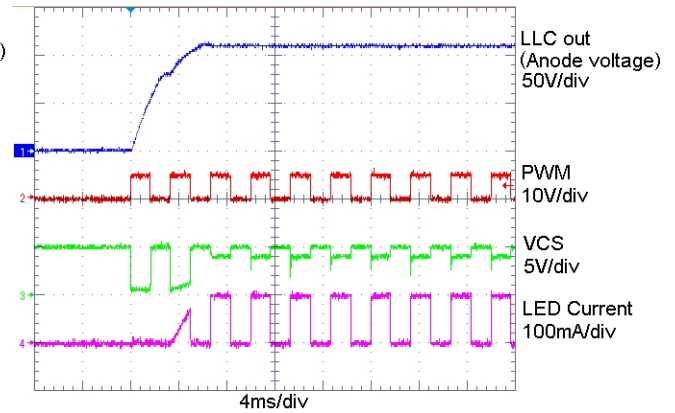

Figure 13. Power Up with 300 Hz PWM

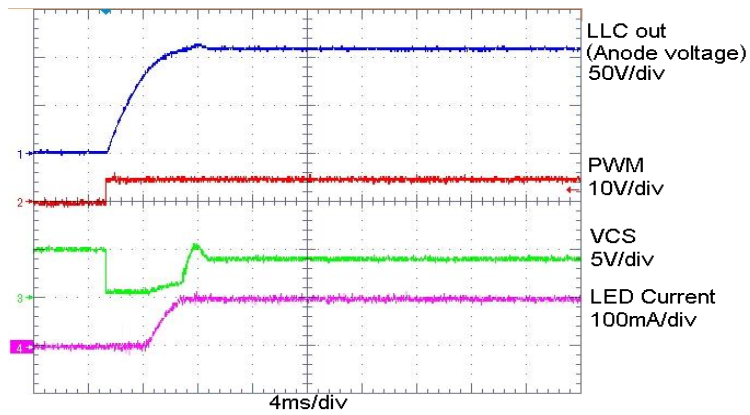

Figure 14. Power Up with PWM Transition High

TYPICAL CHARACTERISTICS

PWM Dimming

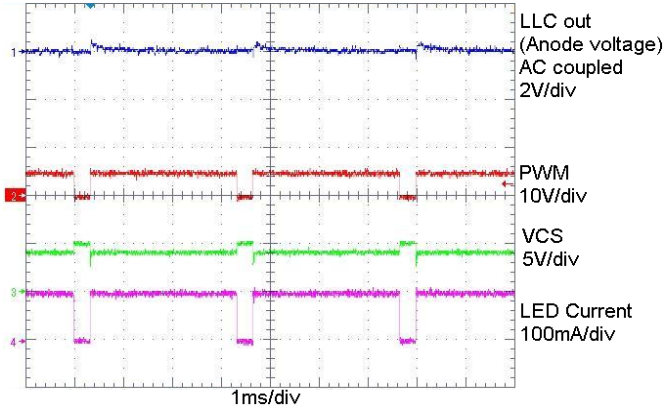

Figure 15. PWM Dimming 300 Hz, 90% Duty Cycle

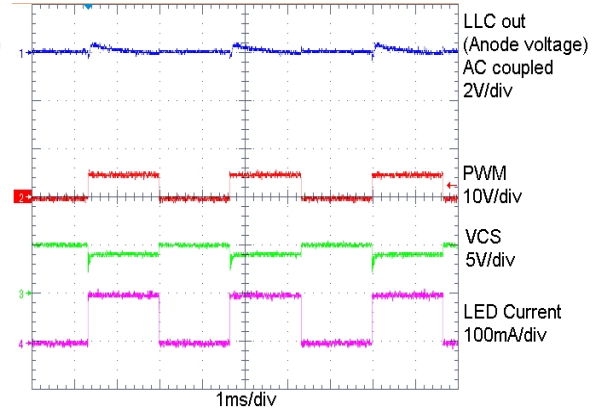

Figure 16. PWM Dimming 300 Hz, 50% Duty Cycle

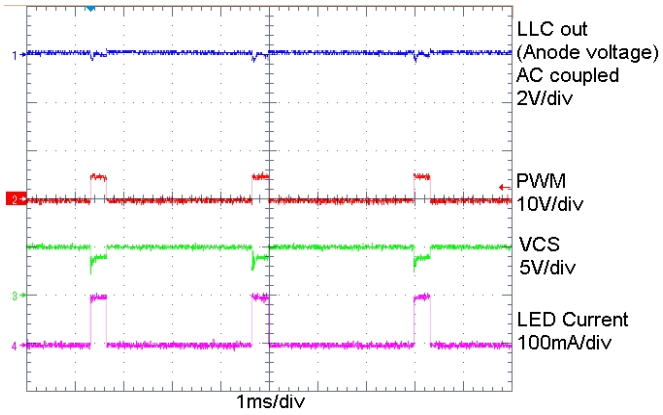

Figure 17. PWM Dimming 300 Hz, 10% Duty Cycle

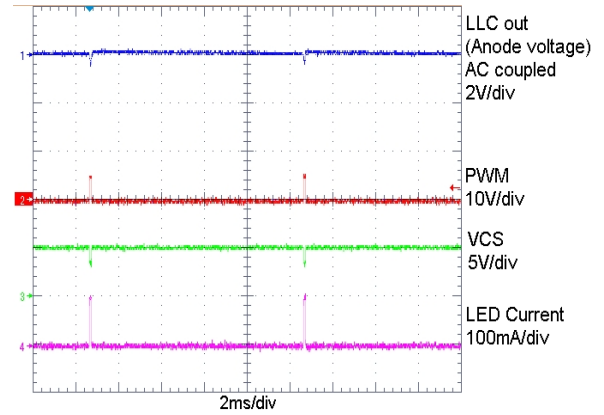

Figure 18. PWM Dimming 100 Hz, 1% Duty Cycle

TYPICAL CHARACTERISTICS

Open LED and Short LED Detections

Figure 19 to Figure 21 show the open LED fault detection during power-up and in normal operation (LED disconnect).

Figure 22 shows the short LED detection, where the FLT-SCA output goes low when there is a voltage mismatch greater than about 28 V between two cathode voltages of any LED strings. Once the SCA fault is triggered, all channels will run at lower current (20% of the nominal current).

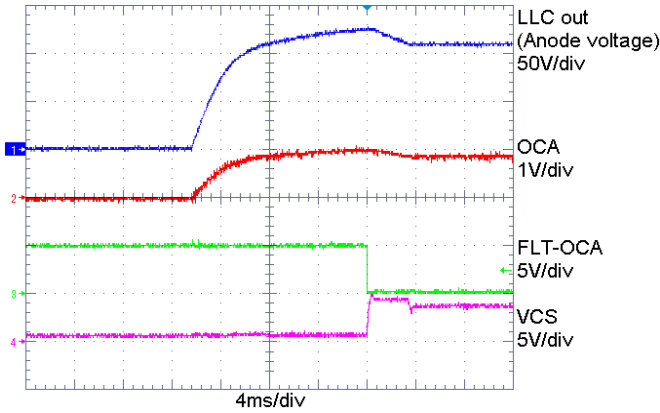

Figure 19. Single Channel Open LED, at Power-up

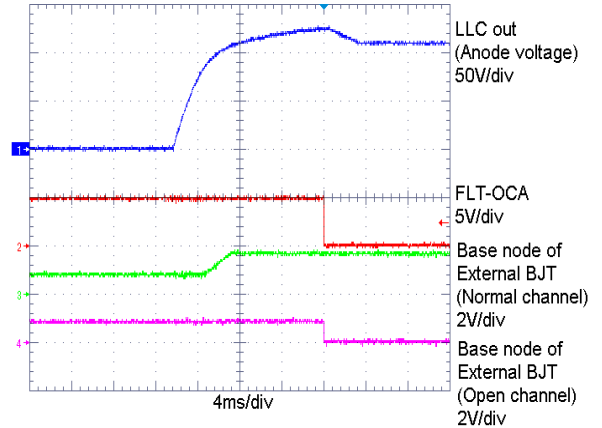

Figure 20. Single Channel Open LED, at Power-up

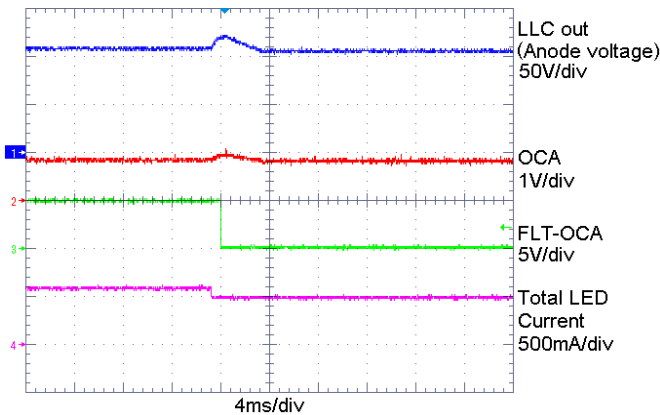

Figure 21. Single Channel Open LED in Operation (LED Disconnect)

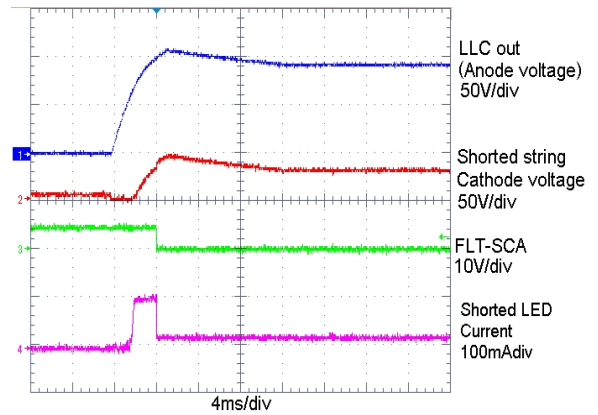

Figure 22. Shorted LED Channel at Power-up

Test Procedure

Warnings:

Due to the very high-voltage present during operation of the boards, power supplies and LED load, the set-up should be handled with care. Make sure the hot side ground (for 400 V and 15 V supplies) is never connected to the cold side ground (for 5 V supply).

When using a separate 400 VDC power supply, it is recommended for safety reasons to set the power supply current limit to 0.4 A.

The following steps are needed for the installation of the set-up.

Connect a 5 V external supply to connector CON3 P1.

Connect the external supply Ground to connector CON3 P2.

Connect the PFC board ground to the connector CON1 P3 & P4.

Connect the PFC board 15 V rail to the connector CON1 P2.

Connect the PFC 400 V rail to the connector CON1 P7 & P8.

Before powering-up the HB-LLC board, an LED load with a total forward voltage of about 100 V (for example 30 LEDs in series with 3.3 V Vf each) should be connected to all the six LED channels on the connector CON2. The connector CON2 includes 6 LED cathode pins and 6 anode voltage pins shorted together.

Warning: It is important to power-up each supply and each board in the correct sequence listed below in order to avoid having the HB-LLC running in open loop; this could happen for example when the PFC is powered prior to the 5 V supply for the CAT4026.

Turn on the 5 V external supply.

Turn on the 15 V external supply.

Turn on the PFC supply unit which provides the 400 V rails.

With the PWM input set high (100% duty cycle), the 5 V supply current should be around 20 mA.

The FLT-SCA and FLT-OCA should be both high.

AND8479/D

Board Schematic

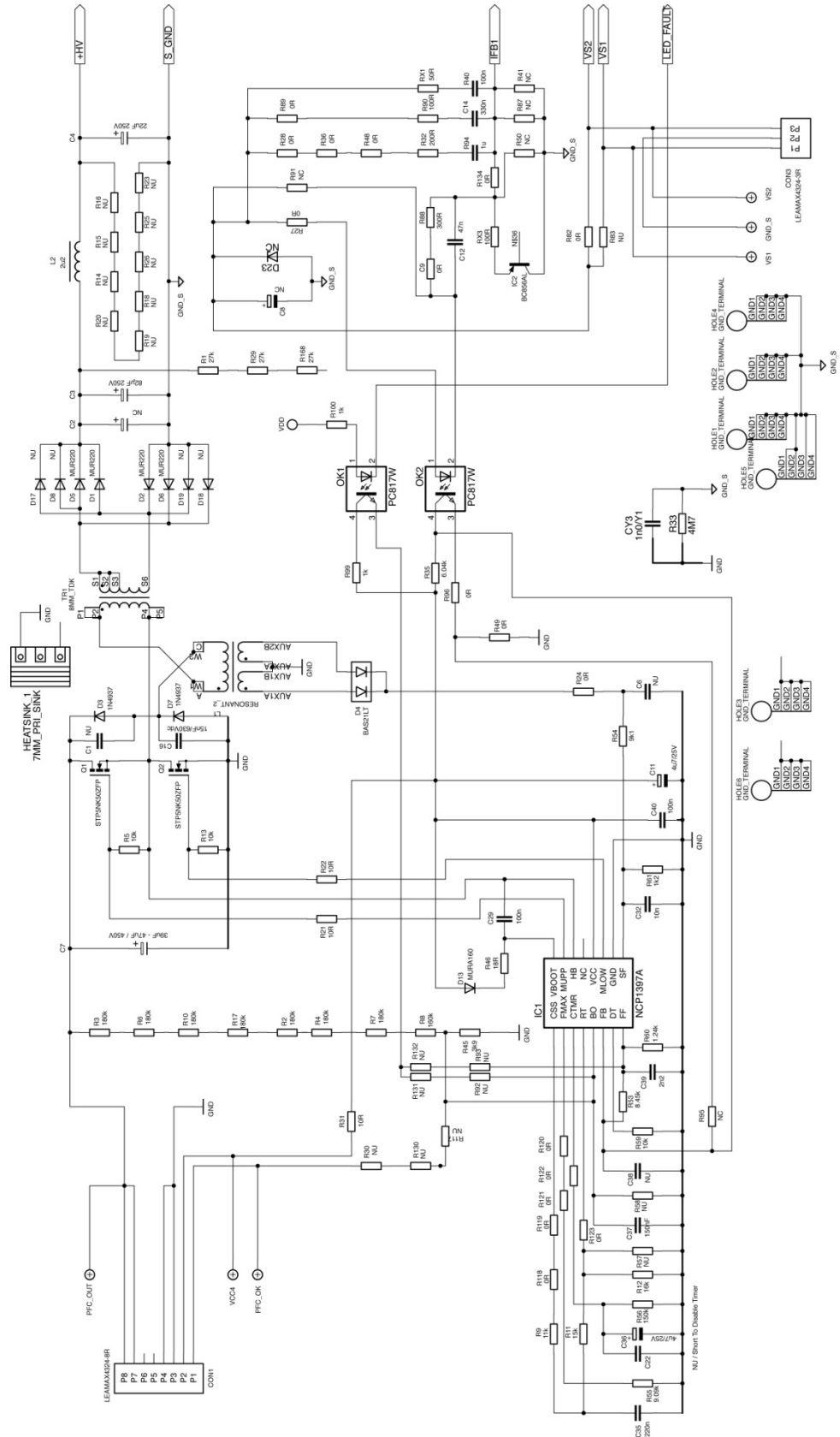

Figure 23. HB-LLC Board Schematic (NCP1397 Section)

AND8479/D

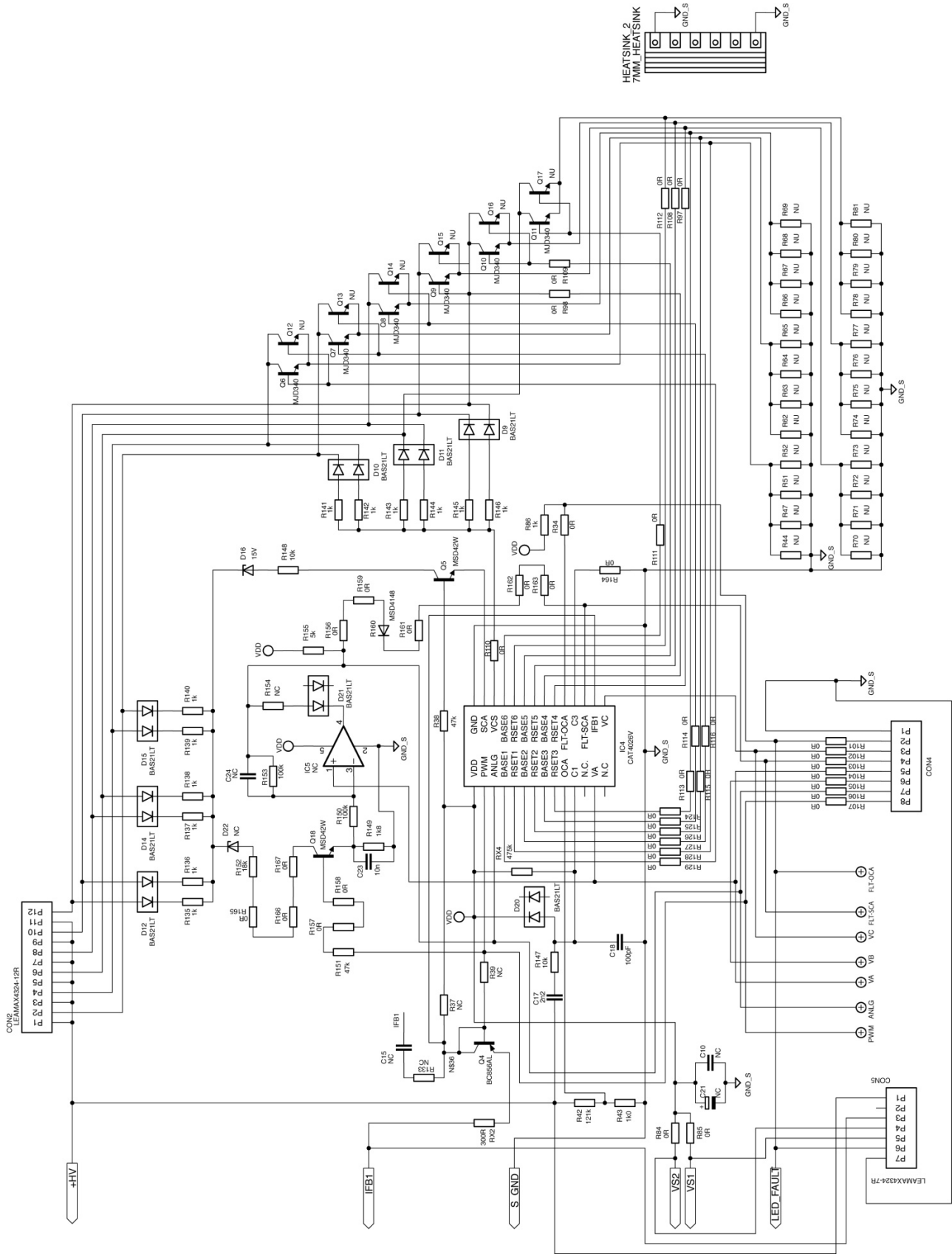

Figure 24. HB-LLC Board Schematic (CAT4026 Section)

AND8479/D

BOARD LIST OF COMPONENTS

Table 2. HB-LLC BOARD LIST OF COMPONENTS

Name	Description	Value	Manufacturer	Part Number	Qty
C1	Electrolytic capacitor	NU	-	-	1
C2	Electrolytic capacitor	82 μ F 250 V, 20%	Nippon Chemicon	EKXJ251BC820MJ40S	1
C3	Electrolytic capacitor	NU	-	-	1
C4	Electrolytic capacitor	22 μ F 250 V, 20%	Nippon Chemicon	EKXG251BC220MJ25S	1
C6, C15, C24, C38	Ceramic capacitor	NU	-	-	4
C7	Electrolytic capacitor	39 μ F 450 V, 20%	Nippon Chemicon	EKXJ451BC390MJ50S	1
C8	Electrolytic capacitor	-	-	-	1
C10, C29, C40, R40	Ceramic capacitor	100 n, 10%	AVX Corporation	08055C104KAZ2A	4
C11, C36	Electrolytic capacitor	4u7/50 V, 20%	Koshin	KLH-50V4, 7 μ F	2
C12	Ceramic capacitor	0.047 μ , 10%	AVX Corporation	08053C473KAT2A	1
C14	Ceramic capacitor	0.33 μ , 10%	AVX Corporation	0805YC334KAT2A	1
C16	Metalized Polypropylene Film Capacitor	15 nF/630 V, 5%	Xiamen Faratronic CO., LTD.	C312J153K60C000	1
C17	Ceramic capacitor	2n2, 10%	AVX Corporation	12062C222KAT2A	1
C18	Ceramic capacitor	100 pF, 10%	AVX Corporation	08051A101KAT2A	1
C21	Electrolytic capacitor	NU	-	-	1
C22	Ceramic capacitor	NU	-	-	1
C23, C32	Ceramic capacitor	10 n, 10%	AVX Corporation	08055C103KAT2A	2
C35	Ceramic capacitor	220 n, 10%	AVX Corporation	08053C224KAT2A	1
C37	Ceramic capacitor	150 nF, 10%	AVX Corporation	08053C154KAT2A	1
C39	Ceramic capacitor	2n2, 15%	AVX Corporation	08055C222KAT2A	1
CY3	Ceramic capacitor	1 nF/Y1, 20%	Murata	DE1E3KX102MA5B	1
CON1, CON4	Connector	-	LEAMAX Enterprise	4324-08R	2
CON2	Connector	-	LEAMAX Enterprise	4324-12R	1
CON3	Connector	-	LEAMAX Enterprise	4324-03R	1
CON5	Connector	-	LEAMAX Enterprise	4324-07R	1
D1, D2, D5, D6	2.0 A, 200 V Ultrafast Rectifier	MUR220	ON Semiconductor	MUR220RLG	4
D3, D7	1 A 600 V Fast-Recovery Rectifier	1N4937	ON Semiconductor	1N4937RLG	2
D4, D9, D10, D11, D12, D14, D15, D20	Switching Diode, 250 V	BAS21	ON Semiconductor	BAS21LT1G	8
D8, D17, D18, D19	200 V Ultrafast Rectifier	NU	-	-	4
D13	Surface Mount Ultrafast Power Rectifier	MURA160	ON Semiconductor	MURA160T3G	1
D16	Zener Diode 500 mW	15 V, 5%	ON Semiconductor	MMSZ15VT1G	1
D21	Switching Diode, 250 V	NU	-	-	1
D22	Zener Diode 500 mW	NU	-	-	1
D23	Zener Diode 500 mW	NU	-	-	1
D24, R160	Switching Diode, 100 V	MMSD4148	ON Semiconductor	MMSD4148T1G	2
HEATSINK_1	Aluminium Heatsink	-	Columbia-Staver	TP209ST,80.0, 7.0.NA,--,02B	1
HEATSINK_2	Aluminium Heatsink	-	Columbia-Staver	TP209ST,120, 7.0.NA,--,02B	1
HOLE1 - HOLE6	Ground Lugs	-	Kang Yang	GND-15	6

AND8479/D

Table 2. HB-LLC BOARD LIST OF COMPONENTS

Name	Description	Value	Manufacturer	Part Number	Qty
IC1	High Performance Resonant Mode Controller with Integrated High Voltage Drivers	NCP1397A	ON Semiconductor	NCP1397ADR2G	1
IC2	General Purpose Transistor PNP	BC856A	ON Semiconductor	BC856ALT1G	1
IC4	6-Channel LED Controller	CAT4026	ON Semiconductor	CAT4026V-T1	1
IC5	Low Input Bias Current, 1.8 V Op Amp	NU	-	-	1
L1	Resonance Coil	100 μ H, 7%	TDK	Y09750-01	1
L2	Inductor	2 μ 2, 20%	Coilcraft	RFB0807-2R2L	1
TR1	Transformer, 5%	-	TDK	X09738-01	1
OK1, OK2	Optocoupler	PC817	Sharp	PC817X2J000F	2
Q1, Q2	N-MOSFET Power Transistor	STP5NK50ZFP	STMicroelectronics	STP5NK50ZFP	2
Q4	General Purpose Transistor PNP	BC856A	ON Semiconductor	BC856ALT1G	1
Q5, Q18	General Purpose High Voltage Transistor NPN	MSD42W	ON Semiconductor	MSD42WT1G	2
Q6, Q7, Q8, Q9, Q10, Q11	High Voltage Power Transistor NPN	MJD340	ON Semiconductor	MJD340G	6
Q12, Q13, Q14, Q15, Q16, Q17	Bipolar Power NPN	NU	ON Semiconductor	MJF47G	6
R1, R29, R168	Resistor SMD	27 k, 1%	Vishay Draloric	CRCW080527K0FKEA	3
R2, R3, R4, R6, R7, R10, R17	Resistor SMD	180 k, 1%	Vishay Draloric	CRCW0805180K0FKEA	7
R5, R13, R59, R147, R148	Resistor SMD	10 k, 1%	Vishay Draloric	CRCW080510K0FKEA	5
R8	Resistor SMD	160 k, 1%	Vishay Dale	CRCW0805160K0FKEA	1
R9	Resistor SMD	11 k, 1%	Vishay Draloric	CRCW080511K0FKEA	1
R11	Resistor SMD	15 k, 1%	Vishay Draloric	CRCW080515K0FKEA	1
R12	Resistor SMD	16 k, 1%	Vishay Draloric	CRCW080516K0FKEA	1
R14, R15, R16, R18, R19, R20, R23, R25, R26, R30, R44, R47, R51, R52, R57, R58, R62, R63, R64, R65, R66, R67, R68, R69, R70, R71, R72, R73, R74, R75, R76, R77, R78, R79, R80, R81, R83, R87, R91, R95	Resistor SMD	NU	-	-	40
R21, R22, R31	Resistor SMD	10 R, 1%	Vishay Draloric	CRCW080510R0FKEA	3
C9, R24, R27, R28, R34, R36, R48, R49, R82, R84, R85, R89, R101, R102, R103, R104, R105, R106, R107, R134, R156, R157, R158, R159, R161, R162, R163, R164, R165, R166, R167	Resistor SMD	0 R, 1%	Vishay Draloric	CRCW08050000Z0EA	31
R43, R86, R99, R100, R135, R136, R137, R138, R139, R140, R141, R142, R143, R144, R145, R146, R154	Resistor SMD	1 k, 1%	Vishay Draloric	CRCW08051K00FKEA	17
R32	Resistor SMD	200 R, 1%	Vishay Dale	CRCW0805200RFKEA	1
R33	Resistor trough hole, High Voltage	4M7, 5%	Welwyn	VRW37-4M7JI	1
R35	Resistor SMD	6.04 k, 1%	Vishay Dale	CRCW08056K04FKEA	1

AND8479/D

Table 2. HB-LLC BOARD LIST OF COMPONENTS

Name	Description	Value	Manufacturer	Part Number	Qty
R38, R151	Resistor SMD	47 k, 1%	Vishay Draloric	CRCW080547K0FKEA	2
R37, R39, R41, R50, R133, R153	Resistor SMD	NU	-	-	6
R42	Resistor SMD	121 k, 1%	Vishay Draloric	CRCW1206121KFKEA	1
R45	Resistor SMD	3k9, 1%	Vishay Draloric	CRCW08053K90FKEA	1
R46	Resistor SMD	18 R, 1%	Vishay Dale	CRCW080518R0FKEA	1
R53	Resistor SMD	8k45, 1%	Vishay Dale	CRCW08058K45FKEA	1
R54, R55	Resistor SMD	9k1, 1%	Vishay Draloric	CRCW08059K10FKEA	2
R56	Resistor SMD	150 k, 1%	Vishay Draloric	CRCW0805150KFKEA	1
R60	Resistor SMD	1k24, 1%	Vishay Draloric	CRCW08051K24FKEA	1
R61	Resistor SMD	1k2, 1%	Vishay Draloric	CRCW08051K20FKEA	1
R88, Rx2	Resistor SMD	301 R, 1%	Vishay Dale	CRCW0805301RFKEA	2
R90, Rx3	Resistor SMD	100 R, 1%	Vishay Dale	CRCW0805100RFKEA	2
R149	Resistor SMD	1k8, 1%	Vishay Draloric	CRCW08051K80FKEA	1
R92, R93, R117, R130, R131, R132	Resistor SMD	NU	-	-	6
R94	Ceramic capacitor	1 μ , 10%	AVX Corporation	08053C105KAT2A	1
R96, R97, R98, R108, R109, R110, R111, R112, R113, R114, R115, R116, R118, R119, R120, R121, R122, R123, R124, R125, R126, R127, R128, R129	Resistor SMD	0R, 5%	Vishay Draloric	CRCW12060000Z0EA	24
R150	Resistor SMD	100 k, 1%	Vishay Draloric	CRCW0805100KFKEA	1
R152	Resistor SMD	18 k, 1%	Vishay Draloric	CRCW080518K0FKEA	1
R155	Resistor SMD	4.99 k, 1%	Vishay Draloric	CRCW08054K99FKEA	1
Rx1	Resistor SMD	49R9, 1%	Vishay Dale	CRCW080549R9FKEA	1
Rx4	Resistor SMD	499 k, 1%	Vishay Dale	CRCW0805499KFKEA	1

AND8479/D

References

1. [CAT4026](#) data sheet
2. [NCP1397](#) data sheet
3. Application note [AND8281/D](#)
4. Application note [AND8255/D](#)
5. Application note [AND8257/D](#)
6. Application note [AND8344/D](#)
7. Application note [AND8241/D](#)
8. Application note [AND8327/D](#)
9. Application note [AND8460/D](#)
10. Bo Yang – Topology Investigation for Front–End DC–DC Power Conversion for Distributed Power System
11. M. B. Borage, S. R. Tiwari and S. Kotaiah – Design Optimization for an LCL – Type Series Resonant Converter

ON Semiconductor and  are registered trademarks of Semiconductor Components Industries, LLC (SCILLC). SCILLC reserves the right to make changes without further notice to any products herein. SCILLC makes no warranty, representation or guarantee regarding the suitability of its products for any particular purpose, nor does SCILLC assume any liability arising out of the application or use of any product or circuit, and specifically disclaims any and all liability, including without limitation special, consequential or incidental damages. "Typical" parameters which may be provided in SCILLC data sheets and/or specifications can and do vary in different applications and actual performance may vary over time. All operating parameters, including "Typicals" must be validated for each customer application by customer's technical experts. SCILLC does not convey any license under its patent rights nor the rights of others. SCILLC products are not designed, intended, or authorized for use as components in systems intended for surgical implant into the body, or other applications intended to support or sustain life, or for any other application in which the failure of the SCILLC product could create a situation where personal injury or death may occur. Should Buyer purchase or use SCILLC products for any such unintended or unauthorized application, Buyer shall indemnify and hold SCILLC and its officers, employees, subsidiaries, affiliates, and distributors harmless against all claims, costs, damages, and expenses, and reasonable attorney fees arising out of, directly or indirectly, any claim of personal injury or death associated with such unintended or unauthorized use, even if such claim alleges that SCILLC was negligent regarding the design or manufacture of the part. SCILLC is an Equal Opportunity/Affirmative Action Employer. This literature is subject to all applicable copyright laws and is not for resale in any manner.

PUBLICATION ORDERING INFORMATION

LITERATURE FULFILLMENT:

Literature Distribution Center for ON Semiconductor
P.O. Box 5163, Denver, Colorado 80217 USA
Phone: 303-675-2175 or 800-344-3860 Toll Free USA/Canada
Fax: 303-675-2176 or 800-344-3867 Toll Free USA/Canada
Email: orderlit@onsemi.com

N. American Technical Support: 800-282-9855 Toll Free
USA/Canada
Europe, Middle East and Africa Technical Support:
Phone: 421 33 790 2910
Japan Customer Focus Center
Phone: 81-3-5773-3850

ON Semiconductor Website: www.onsemi.com

Order Literature: <http://www.onsemi.com/orderlit>

For additional information, please contact your local Sales Representative